



# OWNER'S MANUAL

Model: SE2801



## 28 Inch Electric Smoker

### FOR YOUR SAFETY!

Use outdoors only! Do not use it in a building, garage or any other enclosed areas. Read the instructions before assembling and using the appliance. DO NOT use the grill unless it is completely assembled and all the parts are securely fastened. This grill will become very hot, do not move it during operation. Keep children and pets away.

### CONTACT US FIRST!

This grill has been made to high quality standards. If you have any questions that are not addressed in this manual, or you need parts, please call our customer service hotline or send an email to [service@royalgourmetusa.com](mailto:service@royalgourmetusa.com)

Learn more at:

[www.royalgourmetcorp.com](http://www.royalgourmetcorp.com)

Table of contents ..... 1

Safety Informations ..... 2-3

Explosion View / Parts and Hardwares List ..... 4

Preparation ..... 5

Assembly Instructions ..... 6-8

Operating Instructions ..... 9

Smoking Recipes ..... 10

Warranty and Customer Service ..... 11

- Unit is for **OUTDOOR USE ONLY**.
- Never use inside enclosed areas such as shed, garages, buildings or tents.
- Never operate unit under overhead construction such as roof coverings, carports, awnings, or overhangs.
- Never use unit as a heater.
- Maintain a minimum distance of 10ft (3m) from overhead constructions, walls, rails, or other structures.
- Keep a minimum 10ft (3m) clearance of all combustible materials such as wood, dry plants, grass, brush, paper, or canvas.
- Keep unit clear and free from combustible materials such as gasoline, and other flammable vapors and liquids.
- Use unit on a level, non-combustible, stable surface such as dirt, concrete, brick, or rock.
- Unit **MUST** be on the ground.
- Avoid using unit on wooden or flammable surfaces.
- Never use unit for anything other than its intended use. This unit is **NOT** for commercial use.
- Keep a fire extinguisher accessible at all times while operating unit.
- Before each use, check all nuts, screws, and bolts to make sure they are tight and secure.
- Use of alcohol, prescription or non-prescription drugs may impair user's ability to properly assemble or safely operate unit.
- Keep children and pets away from unit any times. Close supervision is necessary should children or pets be in area where unit is being used.
- Avoid bumping or impacting unit.
- Never move unit when in use. Allow unit to cool completely (below 115°F) before moving or storing.
- The unit is **HOT** while in use and will remain **HOT** for a period of time afterwards and during cooling process. Use **CAUTION**. Wear protective gloves/mitts especially when adding wood.
- Never use glass, plastic, or ceramic cookware in unit. Never place empty cookware in unit while in use.
- Be careful when removing food from unit. All surfaces are **HOT** and may cause burns. Use protective gloves/mitts, or long, sturdy cooking tools.
- Always use unit in accordance with all applicable local, state, and federal fire codes.

### **WARNING:**

1. Do Not place unit on tables or counters.
2. Do Not move unit across uneven ground.
3. Do Not leave unit unattended.
4. Do Not allow children to use unit.
5. Do Not touch **HOT** surfaces.
6. Do Not allow anyone to conduct activities around unit during or following its use until it has cooled.

**When using electrical appliances, basic safety precautions should always be followed including the following:**

- Do not plug in electrical smoker until fully assembled and ready for use.
- Use only approved grounded electrical outlet.
- Do not use during an electrical storm.
- Do not expose electric smoker to rain, or water at anytime.
- To protect against electrical shock do not immerse cord, plug, or control panel in water or other liquid.
- Do not operate any appliance with a damaged cord, or plug, or after appliance malfunctions or has been in any manner. Contact our customer service for assistance.
- Longer detachable power-supply cords or extension cords are available and may be used if care is exercised in their use.
- Longer detachable power-supply cords or extension cord is used:
  1. The marked electrical rating of the cord set or extension cord should be at least as great as the electrical rating of the appliance.
  2. The cord should be arranged so that it will not drape over the counter top or tabletop where it can be pulled by children or tripped over unintentionally.
- The extension cord must be a grounding –type 3-wire cord.
- Outdoor extension cords must be used with outdoor use products and are marked with suffix “W” and with the statement “Suitable for Use with Outdoor Appliance.”
- Do not let cord hand touch hot surfaces.
- Do not place on or near a hot gas or electrical burner, or in a heated oven.
- Fuel, such as charcoal briquettes, or heat pallets, are not to used in electric smoker.
- To disconnect, turn control panel/knob “OFF” then remove plug from outlet.
- Unplug from outlet when not in use and before cleaning. Allow unit to cool completely before adding/removing grates, tray, or water pan.
- Drip tray in only for the bottom of electric smoker. Do not put drip tray on cooking rack, this may damage electric smoker.
- Do not cover cooking grates with metal foil. This will trap heat and cause severe damage to electric smoker.
- Do not clean this product with a water sprayer or the like.

**CAUTION:** To reduce the risk of electric shock, keep extension cord connection dry and off the ground.

# Explosion View / Parts and Hardwares List

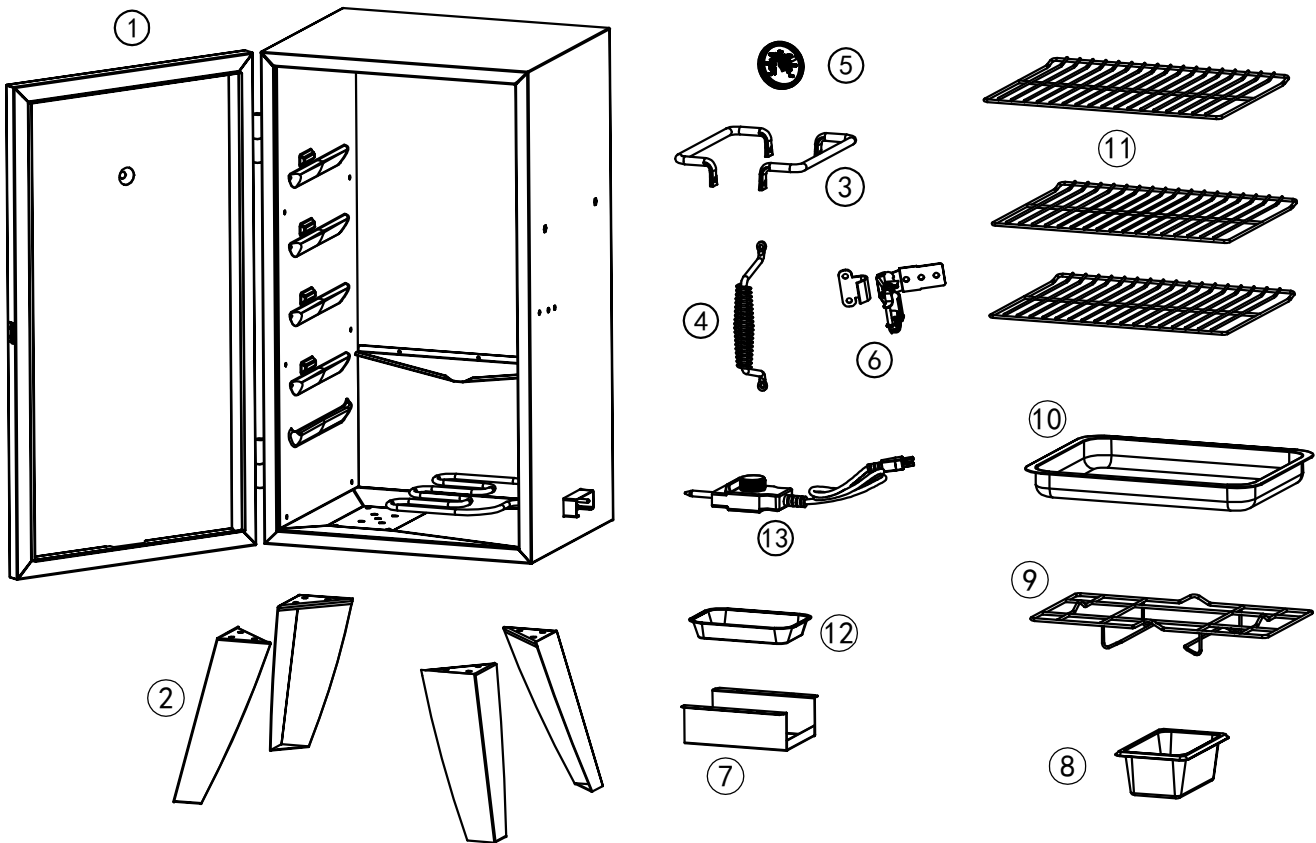

Ref	Description	Illustration	QTY
1.	Main body H-KE162801		1
2.	Leg Z-KE162811		4
3.	Side handle W-KE162801		2
4.	Door handle W-CC183001 W-CC183002		1
5.	Thermometer W-KE162813		1
6.	Door Latch W-KE162804		1
7.	Drip tray base Z-KE162810		1

Ref	Description	Illustration	QTY
8.	Wood chip bowl W-KE162811		1
9.	Wood chip grate W-KE162803		1
10.	Water pan W-KE162816		1
11.	Cooking grate W-KE162802		3
12.	Drip tray W-KE162809		1
13.	Analog controller W-KE162808		1

A	M6x15	18pcs	B	M4x10	9 pcs								

Before beginning assembly, make sure all parts are present. Compare parts with packaged contents list and diagram above. If any parts are missing or damaged, do not attempt to assemble the products. Contact customer service for replacement parts via telephone or email.



Phillips Screwdriver



Wrench

- Estimated assembly time: 15 minutes
- Tools required for assembly:  
Phillips Screwdriver (not included) and Wrench (not included)
- Note: The right and left sides of the grill are designed as if you are facing the front of the grill.



## **CALIFORNIA PROPOSITION 65 WARNING**

1. Fuels used in wood burning appliances and the combustion byproducts of such fuels, can expose you to chemicals including wood dust, which is known to the State of California to cause cancer.
2. This product can expose you to chemicals including nickel, which is known to the State of California to cause cancer.

*For more information go to: [www.P65Warnings.ca.gov](http://www.P65Warnings.ca.gov)*

## Step 1

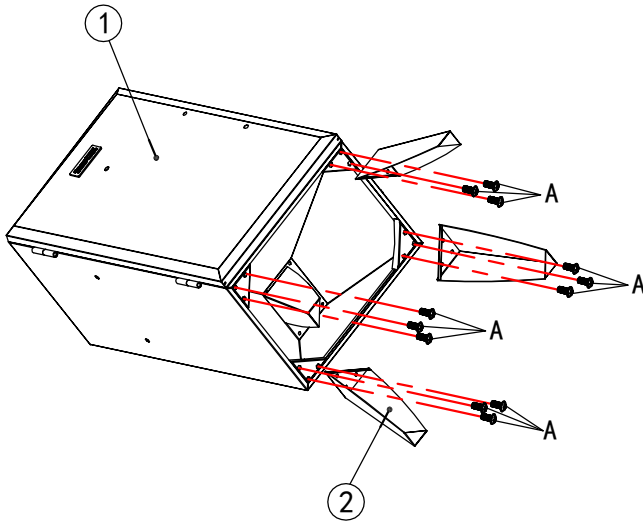

Assemble legs (2) to the bottom of main body (1) with 12 bolts (A).

## Step 2

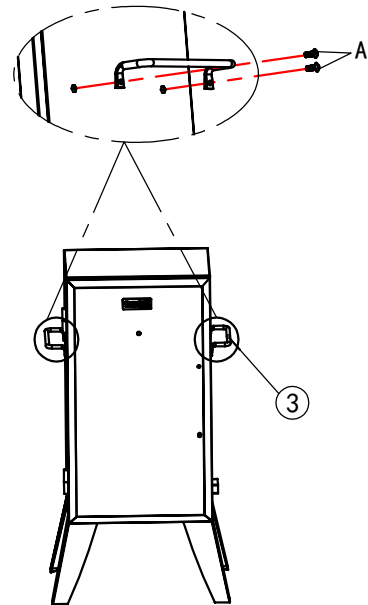

Assemble side handles (3) to side walls of the main body with 4 bolts (A).

## Step 3

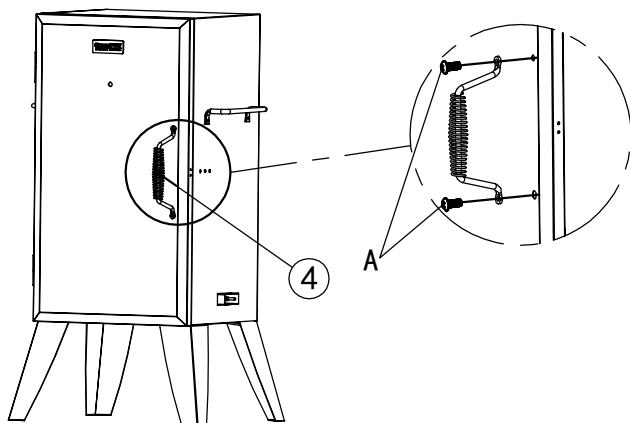

Install door handle (4) to the door of the main body with 2 bolts (A).

## Step 4

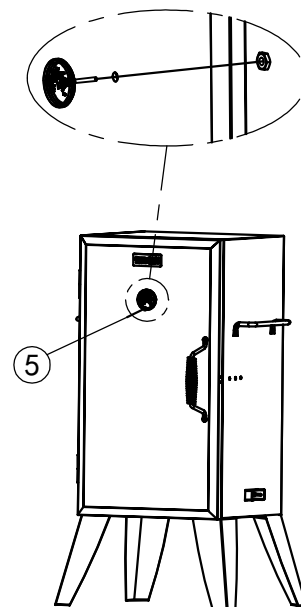

Insert thermometer (5) stem through hole in the door, and secure it with a nut.

**Step 5**

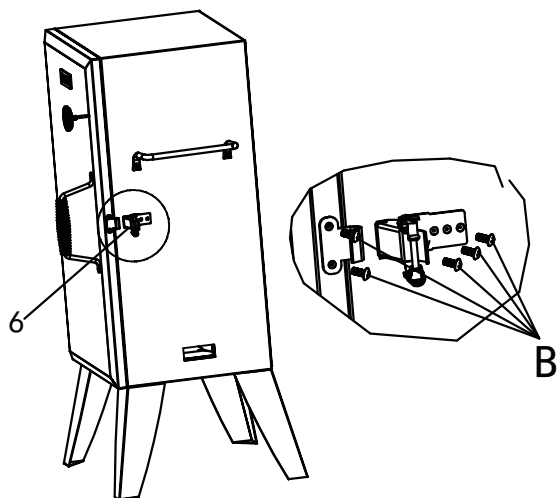

Assemble door latch (6) to side walls of the main body with 5 bolts (B).

**Step 6**

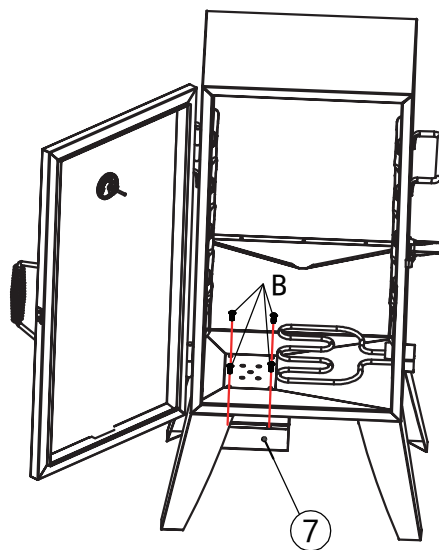

Assemble drip tray base (7) to the bottom of the main body with 4 bolts (B).

**Step 7**

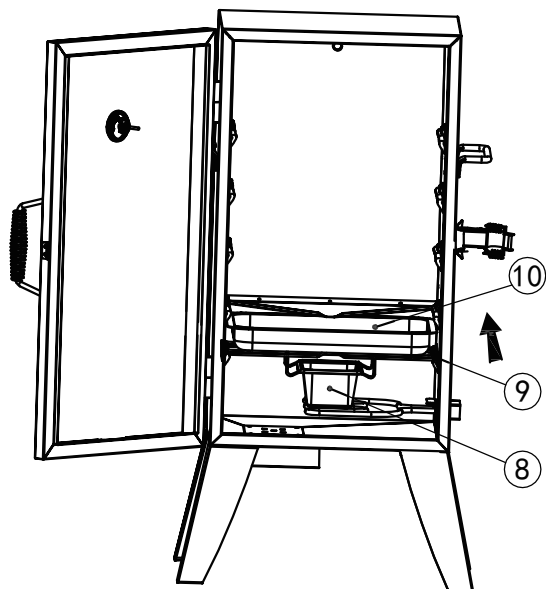

Place wood chip grate (9) into the main body. Place drip tray (8) and water pan (10) to the wood chip grate as shown.

**Step 8**

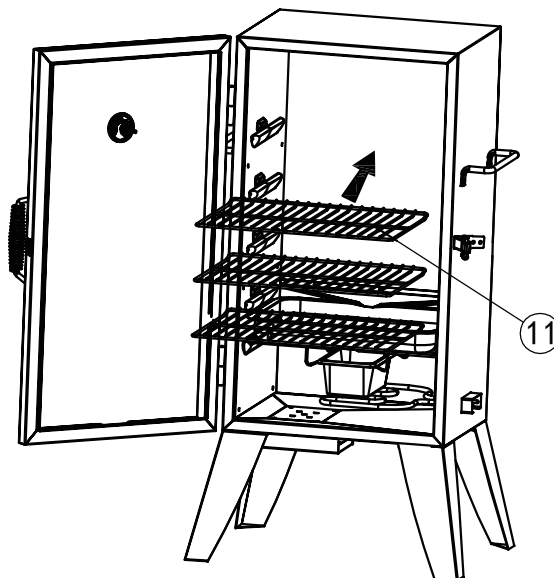

Slide cooking grates (11) onto guides inside main body.



Step 9

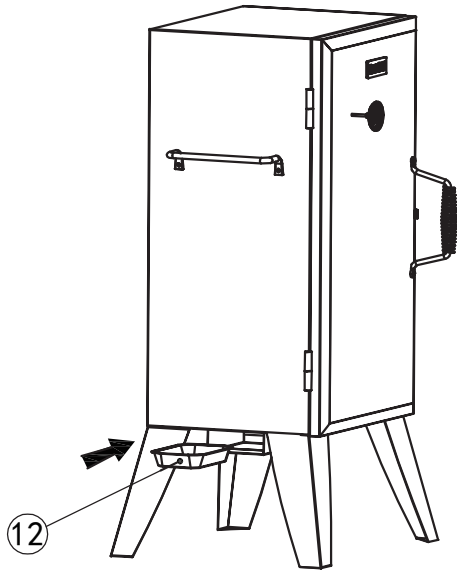

Place drip tray (12) onto the drip tray base underneath the main body.

Step 10

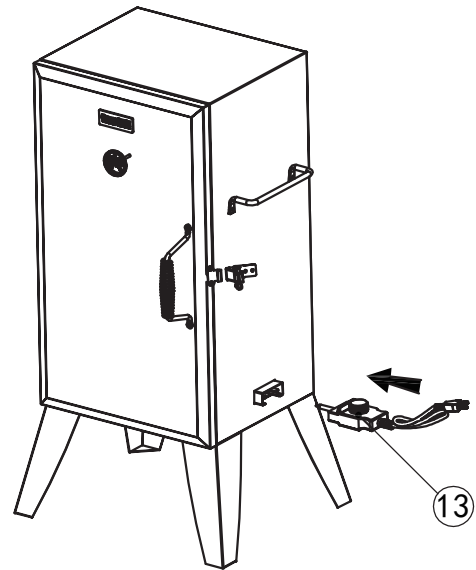

Insert analog controller (13) into side of the main body as shown.

## PRESEASON INSTRUCTIONS

Preseason smoker prior to first use. Make sure water pan is in place with NO WATER. Set control panel to MED and run unit for 3 hours. Shut down and allow to cool. Some smoke may appear during this time, this is normal.

**Note:** During last 45 minutes, add 1 cup of wood chips in wood chip tray to complete pre-seasoning. Wear protective gloves/mitts as the hot surfaces may scald your hands.

### CAUTION

When door is opened a flare up may occur. Should wood chips flare up, immediately close door, wait for wood chips to burn down then open door again. Do not spray with water.

## OPERATING

Step 1: Connect controller to smoker body.

Step 2: Plug power cord into an outlet (refer to "For Your Safety" section of manual).

Step 3: Turn knob to desired setting. Indicator light will turn off when set temperature is reached.

**Note:** Temperature gauge on smoker door reflects setting on controller and displays temperature inside unit.

### Tips for Using Wood Chips

- Pre-soak wood chips in water at least 30 minutes.
- Before starting unit, place 1 cup of wood chips in chip loader.
- Never use more than 1 cup of wood chips at a time. Never use wood chunks.
- Wood chips should be level with top rim of wood chip tray.
- Check wood chip tray periodically to see if wood has burned down. Add more chips as needed.

### Important Facts about Using Smoker

- Maximum temperature will range between 240°F-300°F (120 °C-149°C) when control knob is set on HI.
- Wood chip tray MUST be in place when using smoker. This minimizes the chance of wood flare ups.
- Check drip tray often during cooking. Empty drip tray before it gets full. Drip tray may need to be emptied periodically during cooking.
- Do not open smoker door unless necessary. Opening smoker door causes heat to escape and may cause wood to flare up. Closing the door will re-stabilize the temperature and stop flare up.
- Do not leave old wood ashes in the wood chip tray. Once ashes are cold, empty the tray. Wood chip tray should be cleaned out prior to and after each use to prevent as buildup.
- This is a smoker. There will be a lot of smoke produced when using wood chips. Smoke will escape through seams and turn the inside of smoker black. This is normal. To minimize smoker loss around door, door latch can be adjusted to further tighten door against body.

## SMOKING RECIPES

### SMOKED TURKEY:

- Empty cavity rinse and pat dry with paper towel.
- Tuck wing tips under the back and tie legs together.
- Place in center of cooking grid directly above foil drip pan of water.
- Smoke for 12 minutes per pound. Allow several extra minutes per pound if stuffed to allow for expansion.
- Use a meat thermometer for best results (190F internal).

### SMOKED BAKED HAM:

You can smoke fully cooked canned ham or smoked and cured whole ham or shank or butt portion.

Glaze

1 cup of light brown sugar, firmly packed

1/2 cup orange juice

1/2 cup honey

- Combine sugar, juice and honey. Let glaze sit for at least 4 hours.
- Place fire grate in the lowest position and a drip pan under the meat.
- Remove rind and score fat diagonally to give a diamond effect.
- Insert a whole clove into the center of every diamond.
- Place ham with fat side up in center of cooking grid directly above drip pan. Close lid.
- About 9 minutes per pound is suggested for fully cooked hams. Smoked or cured ham, which is not fully cooked, should be cooked to an internal temperature of 160° F.
- Baste with ham glaze 3 or 4 times during last 30 minutes of cooking time.
- Garnish with pineapple rings about 15 minutes before end of cooking time.

### CHICKEN MARINADE:

Combine

1/2 cup soy sauce

1/4 cup vegetable oil

1/4 cup red wine vinegar

1 teaspoon oregano

1/2 teaspoon sweet basil

1/2 teaspoon garlic powder with parsley

1/4 teaspoon pepper

- Pour over chicken pieces in non-metal dish
- Cover and refrigerate overnight, turning occasionally. Use marinade to baste chicken while cooking.

### MEAT MARINADE: (For steaks, chops, and burgers)

Combine

1/4 cup soy sauce

2 coarsely chopped large onions

2 cloves garlic (halved)

- Combine ingredients in an electric blender, cover, and process at high speed 1 minute or until mixture is very smooth.
- Stir in 1/4 cup bottle gravy coloring (Kitchen Bouquet and Gravy Master) and 2 teaspoons Beau Monde seasoning (or substitute 1 teaspoon MSG and 1 teaspoon seasoned salt).
- Allow meat to stand in marinade at room temperature for 2 hours or refrigerate up to 24 hours in a covered dish.
- Bring meat to room temperature before cooking.

### SMOKED HOT DOGS STUFFED:

- Slit hot dogs lengthwise, within 1/4 inch of each end.
- Stuff hot dogs with cheese and relish and wrap in bacon.
- Place on cooking grid over drip pan and smoke 15-20 minutes or until bacon is crisp.

### SMOKED HOT DOGS STUFFED:

- Rinse pieces in cold water and pat dry with paper towels.
- Brush each piece with vegetable oil and season to taste with salt and pepper.
- Brown pieces directly above coals with lid open and grate in high or medium position for several minutes.
- Then place pieces on cooking grate directly above drip pan.
- With the grate in the low position, cook with lid down for 55 to 60 minutes or until done. Do not use vegetable oil or salt and pepper if using marinade.

### SMOKED SHRIMP & CRAYFISH:

- Mix in a foil pan 1/2 cup butter, two cloves of crushed garlic, Tabasco, sliced green pepper, 1 tablespoon each of minced onions, salt and juices from one lemon.
- Add shrimp and/ or crayfish and smoke 45 minutes.

### SMOKED VEGETABLES:

- Turnips, potatoes, carrots, okra, mushrooms, peeled onions, zucchini, squash, etc.
- Put in pan and cover with water and cook for several hours while cooking the meat. Or place vegetables on grill and smoke for 50 minutes, either wrapped in foil or not.

### SMOKED FISH:

- Marinate in brine (1/4 cup dissolved in 1 qt of water) or marinate fish in 1 cup white wine, 1 cup soy sauce mixed with 1 cup lemon juice.
- Marinate overnight in covered dish in refrigerator.
- Let air on rack 20 minutes before placing on Pam-sprayed grill.
- Smoke 25 minutes.

### SMOKED SPARE/BACK RIBS:

- Peel off tough layer of skin on back side.
- Rub all surfaces with seasoning.
- Place ribs in center of grid above drip pan and smoke approximately 1 1/2 hours or until meat pulls away from bone.
- Baste with barbecue sauce during last 30 minutes.

### SHISH KABOB MARINADE:

Mix

1 cup soy sauce

1/2 cup brown sugar

1/2 cup vinegar

1/2 cup pineapple juice

2 teaspoons salt

1/2 teaspoon garlic powder

- Mix ingredients and bring to a boil.

- Marinate beef in mixture a minimum of 4 hours.

Thanks for purchasing this Royal Gourmet® Smoker. We are here to help you maximize your enjoyment and appreciation of your new grill. We provide a warranty for your product within the framework warranty condition under normal use of one year from the date purchase for all components covering defects and manufacturing errors.

Royal Gourmet's obligations are limited to the following:

- This warranty does not cover grills that have been altered or damaged due to normal wear, rust, abuse, improper maintenance, improper use, or modifications to the product. Repair labor is not covered.
- This warranty does not cover surface scratches or heat damage to the finish which is considered normal wear.
- All warranty claims apply only to the original purchaser and require a proof of purchase verifying date of purchase.
- All parts that meet the warranty requirements will be shipped at no-charge via the discretion of the customer service department.
- Do not return parts without prior to obtain obtaining return authorization from our customer service department.

Except as stated above, Royal Gourmet Corp makes no other express warranty.

This warranty may give you specific legal rights that vary by state.

Please do not hesitate to contact our customer service when you have any questions regarding assembly, warranty, or accessories. We will be happy to offer any replacement parts you need during the time of warranty period.



1-800-618-6798



[service@royalgourmetusa.com](mailto:service@royalgourmetusa.com)



Mon - Fri, 8:30 AM- 5:30 PM, EST